

---

# WHY ACCEPT POWER BUDGET CONSTRAINTS?

---

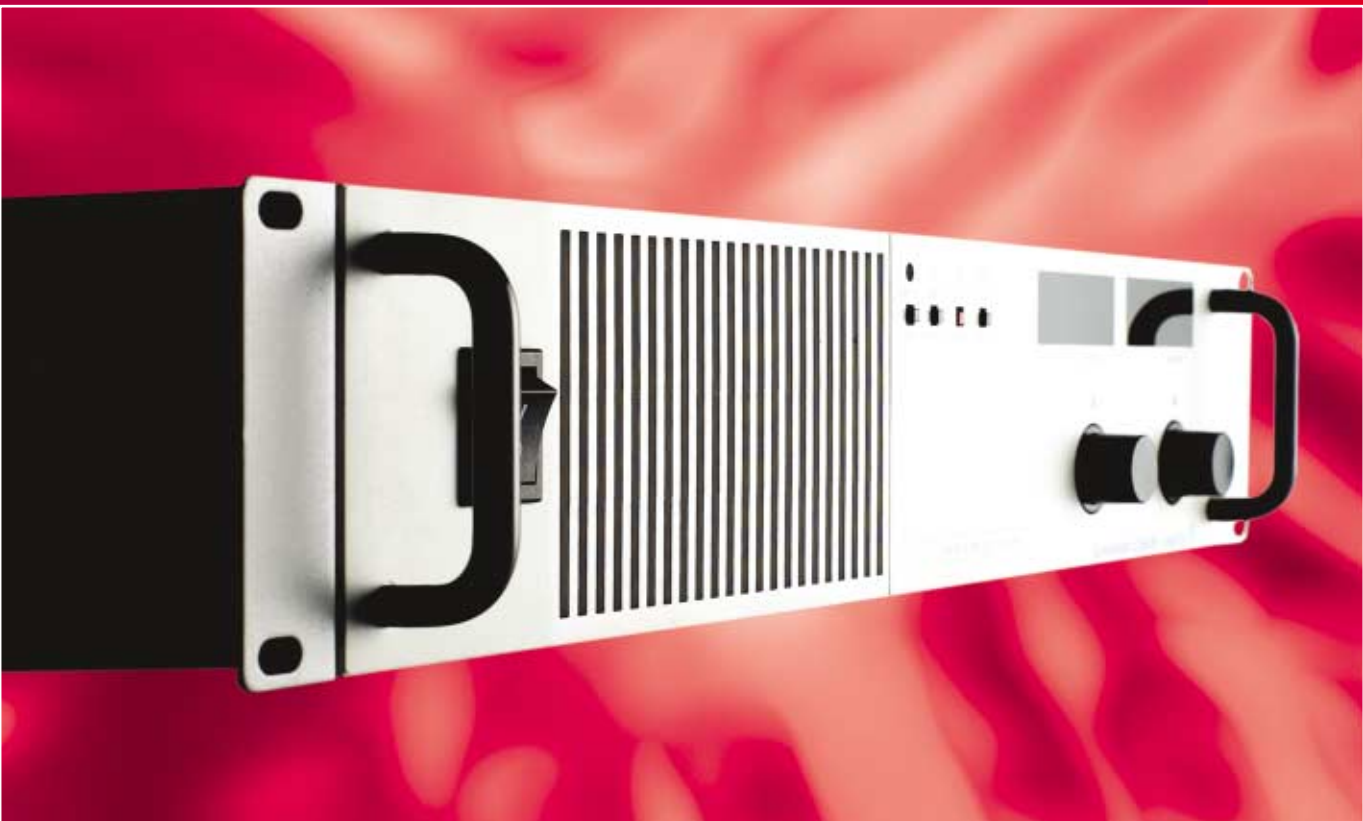

## Glassman Europe LP series 2.8 kW low voltage DC power supplies

---

- Zero voltage “soft” switching for high efficiency, low noise and high reliability
- Analogue programming standard, optional ISOL card
- Optional internal 16-bit GPIB (IEEE 488) and RS-232 control
- OVP, current limit, thermal protection
- Labview® and LabWindows® drivers
- Remote sense, 5 V line loss compensation
- Constant voltage or constant current operation with automatic crossover mode indication

# ELECTRICAL SPECIFICATIONS

## INPUT

190-264 VAC, 1 $\phi$  (22.6 A @ 208 VAC; 20.5 A @ 230 VAC typical), 47-63 Hz.

## EFFICIENCY

See models chart.

## OUTPUT

Continuous stable adjustment from zero rated voltage and current by user-selectable external source (V,I or R), or panel-mounted 10-turn potentiometers, Analogue programming linearity <1%, potentiometer control resolution 0.02%.

## REMOTE SENSE (Line drop compensation)

5 V/line (Line Drop is subtracted from total voltage available at supply output).

## REGULATION, LINE

Voltage: 0.01% of Vmax + 2 mV.  
Current: 0.01% of Imax + 2 mA.

## REGULATION, LOAD

Voltage: 0.02% of Vmax + 5 mV.  
Current: 0.02% of Imax + 5 mA.

## RIPPLE

See models chart.

## STABILITY

0.05% per 8 hours; with constant line, load and temperature after 30 minute warm-up.

## OVERVOLTAGE PROTECTION

5% to 110% of Vmax.

## TEMPERATURE COEFFICIENT

Voltage: 0.02% of Vmax/°C.  
Current: 0.03% of Imax/°C.

## AMBIENT TEMPERATURE

Operating: 0-50°C with full compliance to specifications. Storage: -20 to +70°C.

## HUMIDITY RANGE

30 to 90% RH, non-condensing.

## VOLTAGE MODE TRANSIENT RESPONSE

<3ms for output voltage to recover to within 0.5% of its rated voltage after a step change in load current of up to 10% to 90% of rated output.

## REMOTE ENABLE/DISABLE AND INTERLOCK

2.5 - 15 V signal or TTL - compatible input, selectable logic.

## TIME DELAY FROM POWER ON UNTIL OUTPUT IS STABLE

7 s maximum.

## SWITCHING FREQUENCY

Nominal 31 kHz (62 kHz output ripple).

## OUTPUT TERMINAL ISOLATION

600V DC from output to safety ground.

## LP Series 2.8 kW models

Model	Output Voltage	Output Current	Ripple Voltage	Ripple Voltage	Ripple Current	Efficiency	Options
	VDC	A	p-p(0-20MHz)	RMS	RMS		
LP7.5-300	0-7.5	0-300	50mV	4mV	400mA	81%	<b>ISOL:</b> Isolated Interface card provides isolated analogue control and read-back of output voltage and current. <b>GPIB:</b> Internal GPIB Interface card (16 bit) <b>RS232:</b> Internal RS-232 Interface card (16 bit) <b>ISOL-420:</b> 4-20 mA isolated analogue control. <b>M2:</b> 208 VAC 3 $\phi$ input. <b>M13A:</b> Locking knobs for front panel controls.
LP12-220	0-12	0-220	50mV	5mV	200mA	84%	
LP20-130	0-20	0-130	60mV	6mV	100mA	87%	
LP40-70	0-40	0-70	60mV	6mV	50mA	86%	
LP60-46	0-60	0-46	60mV	6mV	30mA	88%	
LP100-28	0-100	0-28	75mV	12mV	10mA	89%	
LP150-18	0-150	0-18	100mV	15mV	5mA	90%	
LP300-9	0-300	0-9	120mV	20mV	5mA	90%	
LP600-4	0-600	0-4	200mV	35mV	0.7mA	90%	

## Optional Internal GPIB/RS232 Interface Specifications

	Voltage mode		Current mode	
	Resolution	Accuracy	Resolution	Accuracy
Program	0.01% of V max	0.20% + 10mV	0.01% of I max	0.30% + 10mA
Readback	0.01% of V max	0.20% + 20mV	0.01% of I max	0.30% + 20mA

# MECHANICAL SPECIFICATIONS

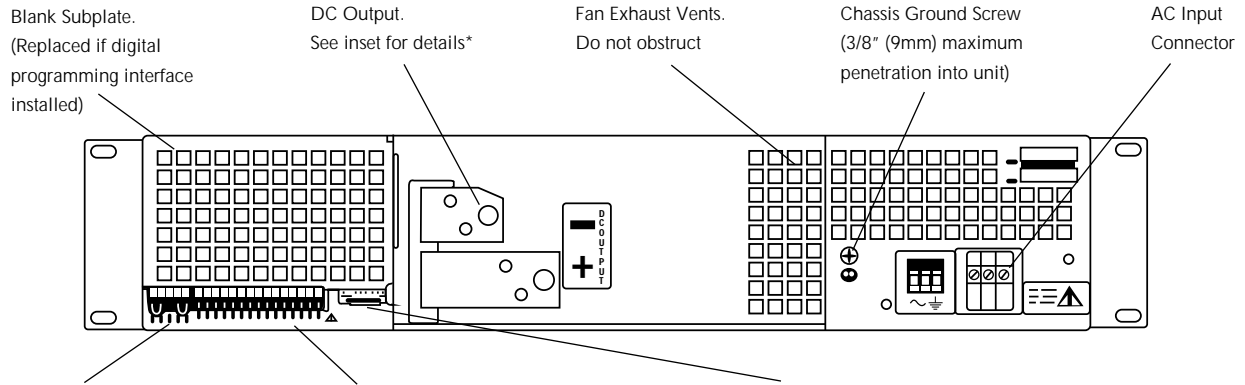

- J10 Sense Connector
1. Return Sense
  2. Negative Output (Return)
  3. No Connection (N/C)
  4. Positive Output
  5. Postive Sense

- J2 Programming and Monitoring Connector
1. Remote Output Voltage Programming Select
  2. Remote Output Current Limit Programming Select
  3. Control Ground
  4. N/C
  5. Voltage Program Signal Return
  6. Output Voltage Program Input
  7. Current Program Signal Return
  8. Output Current Limit Programming Input
  9. Voltage Monitor Signal Return
  10. Output Voltage Monitor
  11. Current Monitor Signal Return
  12. Output Current Monitor
  13. N/C
  14. Shutdown (S/D) Signal Return (-)
  15. S/D Input (+)

- SW1 Switch
1. Resistive Programming of Output Voltage
  2. Resistive Programming of Output Current Limit
  3. Output Voltage Programming Source Range
  4. Output Current Limit Programming Source Range
  5. Output Voltage Monitor Range
  6. Output Current Monitor Range
  7. Remote Shutdown Logic
  8. Over Temperature Reset Mode

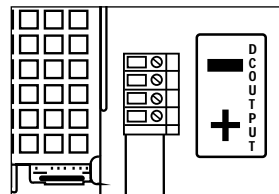

\*Output Voltage Connector  
For High Voltage  
(150V to 600V) Models

## Dimensions

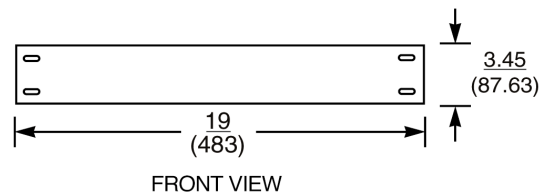
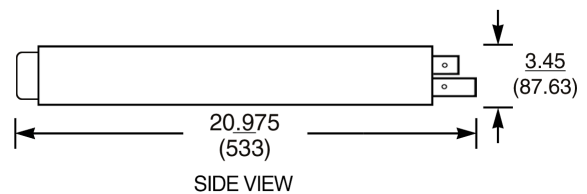
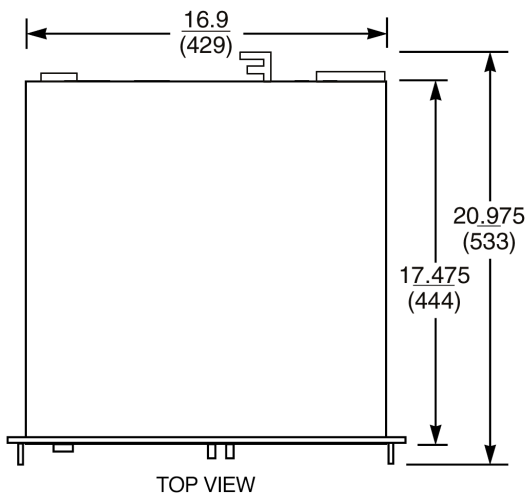

(Inches  
mm)

### Warranty

Glassman Europe Limited warrants standard power supplies to be free from defects in materials and workmanship for three years from the date of shipment. The Company agrees to replace or repair any power supply that fails to perform as specified within the warranty period. Formal warranty available.



21 Campbell Court  
Campbell Road, Bramley,  
Tadley, Hampshire RG26 5EG  
Telephone: (01256) 883007  
Fax: (01256) 883017

Cost-effective and compact, the 2.8kW LP series delivers full-featured performance. A quick glance at the

front panel demonstrates sophisticated functionality and user-friendly controls and status indicators:



OVP Setting Preview Switch (OVP CHECK)

Local Voltage & Current Limit Setting Preview Switch (V/I CHECK)

Standby Switch

Return to Local Programming (LOCAL)  
(For units with digital programming interface installed)

ACTUAL SIZE

AC mains Power Switch

# ...THE 2.8kW LP SERIES HAS PLENTY TO SPARE



- OVP Adjustment Potentiometer (OVP SET)
- OVP Shutdown LED (OVP)
- Shutdown LED (S/D)
- Remote Programming LED (REM)
- Over Temperature Protection LED (OTP)
- AC Fail LED (ACF)

Remote Programming LEDs.  
(For units with digital programming  
interface installed)

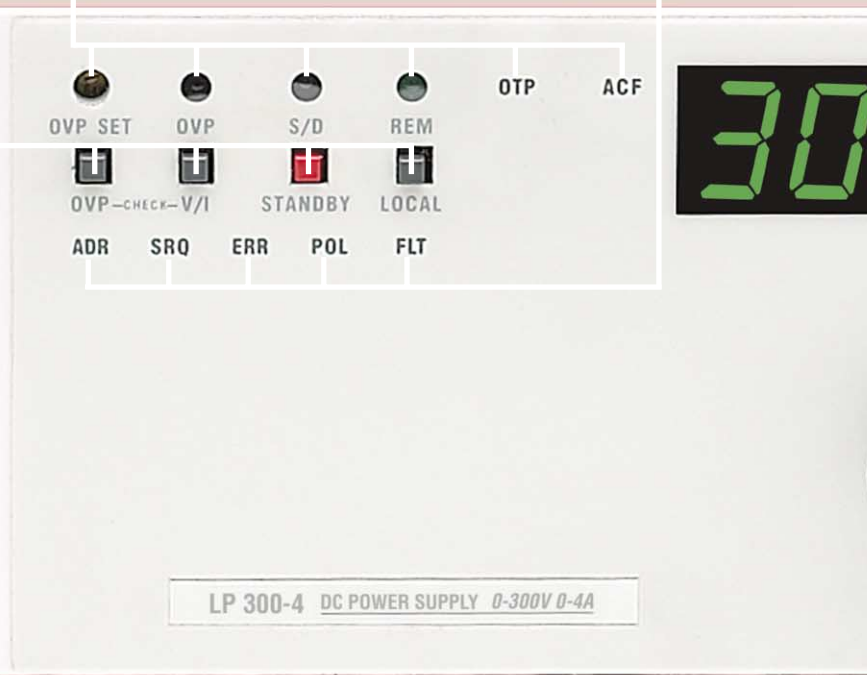
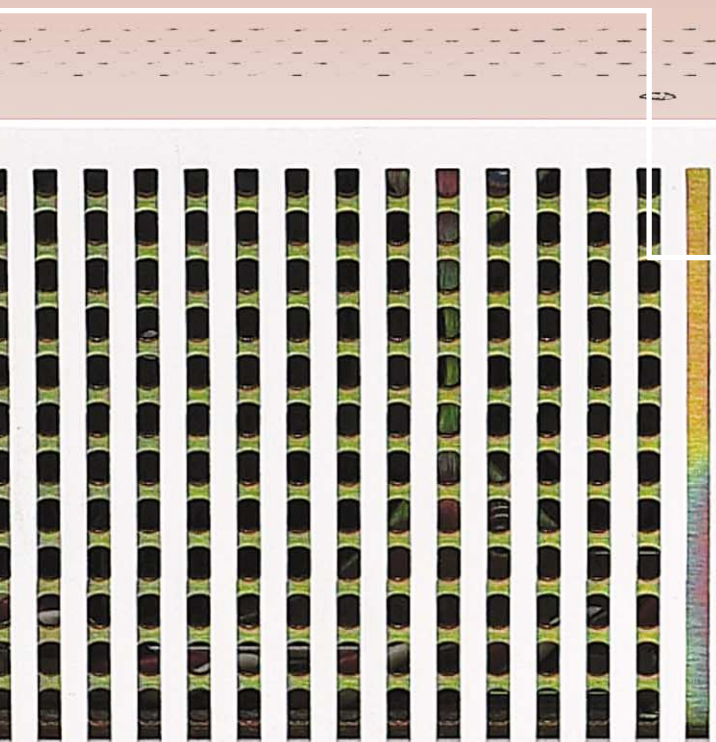

To complement the local controls and indicators, there are an equally impressive number of remote control/status interface points for optimum flexibility. Not only do we provide you with full remote analogue control capability as standard, we also

provide an internal switch to select the format or full-scale control range. Output voltage and current can be controlled (0-full scale) via resistance (0-5k $\Omega$ ); voltage (0-5V DC) or (0-10V DC); or current (0-1mA).

3 $\frac{1}{2}$ -digit LED displays for both voltage and current

Voltage Mode LED  
Current Mode LED



Output Voltage Control Knob

Output Current Control Knob